

PRORIL

50Hz

GOVOX-U Series, these vortex pumps feature a less impeller wear and longer pump life by a vortex flow that allows fibrous materials and solid matters to be pumped out without obstruction.

Sewage Pump

GOVOX-U 322/337

Vortex Pump



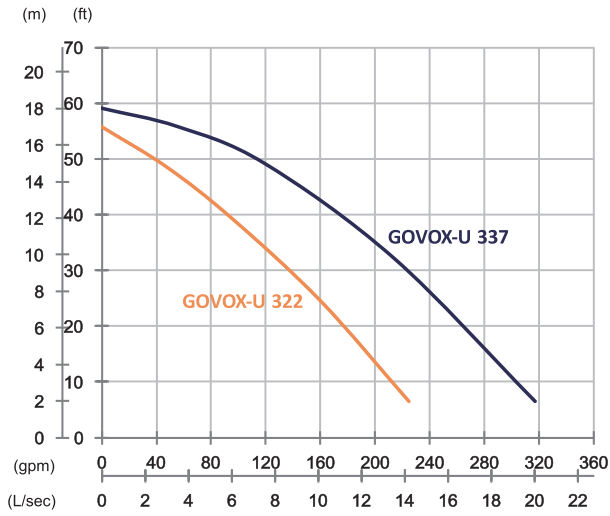

	GOVOX-U 322	GOVOX-U 337
OUTPUT	2.2 kW (3 HP)	3.7 kW (5 HP)
OUTLET	3" (80 mm)	3" (80 mm)
SOLID PASSAGE	55 mm	55 mm
Weight	40 kg	49 kg
HEAD	Rated: 12 m Max: 17 m	Rated: 15 m Max: 18 m
FLOW	Rated: 6 L/s Max: 14.2 L/s	Rated: 7.5 L/s Max: 20 L/s

Pump Type		Electric Submersible Pumps
Motor	Phase	3-Phase
	Type	Induction Motor
	Poles	2 Pole (2850 rpm)
	Insulation	Class F
	Protector	Circle Thermal Protector
	Starter	D.O.L.
Lubricant		Food Grade (ISO VG32)
Specs.	Impeller Type	Vortex
	Shaft Seal	Double Mechanical Seal
		Silicon Carbide VS Ceramic/Carbon
	Bearings	C3 Shielded ball bearings
	Cable	H07RN-F
10 m or longer upon request		
Materials	Pump Casing	Ductile Iron
	Impeller	Gray Iron
	Motor Frame	Gray Iron
	Motor Shaft	Stainless Steel
Max. Liquid Temperature		40°C (104°F)
Max. Submersion Depth		20 m (66ft)
pH Range		pH 5 - pH 8

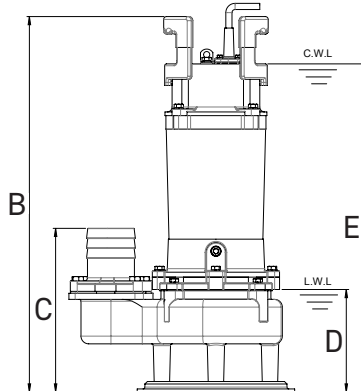
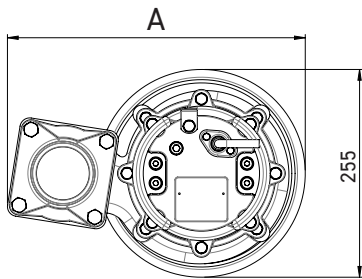

unit : mm

C.W.L : Continuous running water level
L.W.L : Lowest running water level

	A	B	C	D	E
GOVOX-U 322	366	660	265	150	531
GOVOX-U 337	376	717	274	159	589